

ACORN SOFT

ATOMCALC MANUAL

C8 V ATOMCALC
B8+.15
←

EXPENSE	COST	VAT	TOTAL
FOOD	63.39	0.00	63.39
GAS	12.00	1.80	13.80
ELECT.	33.20	4.98	38.18
PHONE	7.10	1.06	8.16
RENT	95.85	14.37	110.22
PETROL	47.10	7.06	54.16
INSURE.	23.11	3.46	26.57
EXPENSES			314.50
INCOME			325.00
SPENDING			10.49

ATOMCALC MANUAL

CONTENTS	Page
1 Introduction.....	2
2 Entering and Re-entering ATOMCALC.....	3
3 Writing and Assigning Data.....	5
4 Replicating.....	11
5 Deleting and Changing Entries.....	16
6 Presenting Data.....	16
7 Saving, Loading and Printing.....	18
8 Example: A Cash Flow Forecast.....	21
Subject index.....	28
Summary of commands.....	Back cover

1 Introduction

ATOMCALC will transform your ATOM into an "electronic sheet" which is capable of storing data in a logical and consistent format, and performing complex calculations using stored data.

ATOMCALC's memory is arranged in rows and columns like a page of a ledger. The grid consists of 62 columns and 255 rows: the columns are lettered A to BK, and the rows are numbered from 1 to 255. A single entry on the electronic sheet is referred to by its column and row address or 'grid reference', for example, "B20". Entries can be up to 32 characters in length, and can contain numbers, letters, or mathematical equations.

On the financial and business side ATOMCALC is well-suited to keeping records, book keeping on a small or large scale, calculating end-of-year accounts, and testing hypotheses relating to data; for example, scheduling and predicting cash flow.

Where science and engineering projects are concerned ATOMCALC incorporates a scientific calculator which features the standard mathematical and trigonometrical functions and constants, including SIN, COS, TAN, ASIN, ACOS, ATAN, ABS, LOG, PI, EXP, SQR, and RND. The calculator will apply stored formulae to subsequent entries, and recalculate existing entries as new data is entered on the sheet.

Knowledge of programming, or a programming language, is not essential - ATOMCALC's language consists of a set of simple commands. A summary of these appears on the back cover for quick reference.

Data can be saved on cassette, and the contents of the electronic sheet can be printed out in tabular form as displayed, or as a straightforward listing.

<p>*Examples occurring in the main text of this manual are printed within boxes.</p>
--

Memory requirements

ATOMCALC will make use of as much lower text space as is available from #2800 upwards; it also requires the presence of the ATOM Floating-point ROM.

2 Entering and Re-entering ATOMCALC

To enter ATOMCALC type the word "CALC", and then press RETURN. The white header and cursor will appear at the top of the display as shown in the photograph:

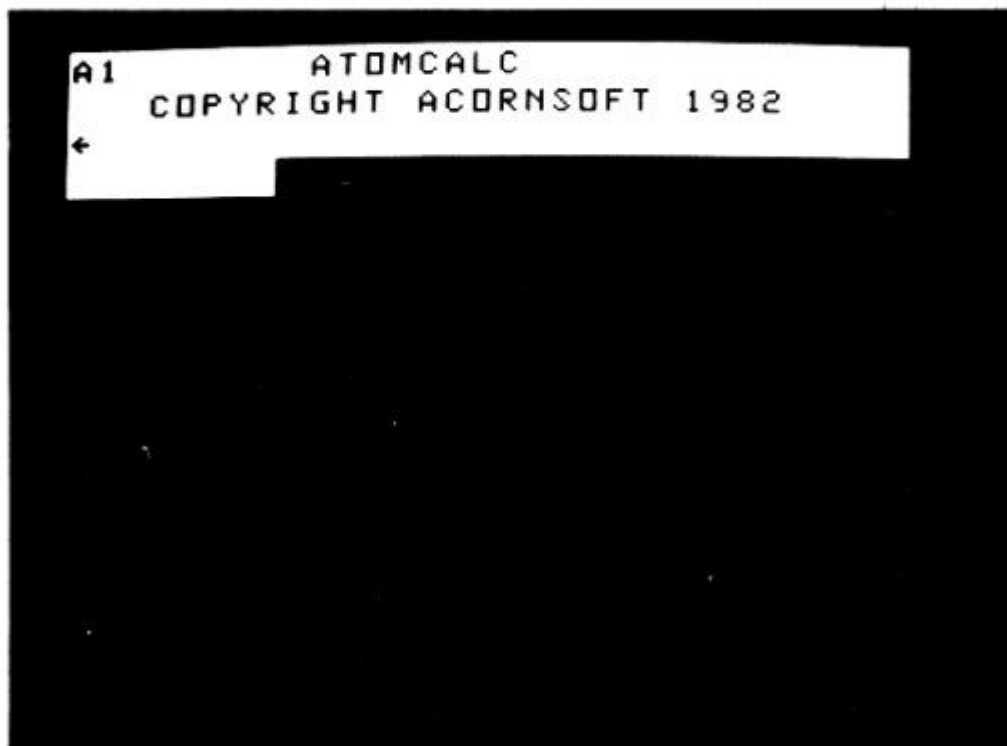

To leave ATOMCALC and return to BASIC press the BREAK key.

Whenever you use the CALC command, ATOMCALC's memory is cleared. To re-enter ATOMCALC preserving all sheet entries enter "CALCR", (and then press RETURN). The data on the sheet is displayed when you press LOCK.

BEWARE OF THE BREAK KEY.....if you hit the BREAK key by mistake and you want to re-enter ATOMCALC at the position you left it, remember to use CALCR and then LOCK, or you could lose your work to date.

The header

The header is three lines deep and 32 characters wide. A grid reference is displayed in the top left hand corner (A1 to start) and the word ATOMCALC in the middle. Initially the second line displays a copyright message which will disappear when you begin using the system. The third line shows the ATOMCALC prompt (←) which follows information as it is typed in.

The display

Data is entered in the area beneath the header. This area is best thought of as a 'window' which looks at one section of the electronic sheet at a time - the sheet itself is far too big to be displayed all at once. The section displayed is 13 rows deep and (initially) 4 columns wide.

	A	B	C	D	E	F	G	H	END
1										
2										
3										
4										
5										
6										
7										
8										
9										
10										
11										
12										
13										
14										
15										
16										
17										
18										
19										
20										
21										
22										
23										
24										
25										
26										
27										
28										
29										
30										
31										
32										
33										
34										
35										
36										
37										
38										
39										
40										
41										
42										
.										
.										
.										
.										
.										
255										

The cursor

The cursor is the white rectangle initially displayed at position A1. It highlights one 'cell' on the electronic sheet at a time, and its current grid reference is displayed at line 1 of the header.

The cursor can be moved to any position on the electronic sheet using the arrow keys in conjunction with the SHIFT key:

↔ cursor right

SHIFT ↔ cursor left



cursor up

SHIFT cursor down

↔ and ↑ are auto-repeat keys, and so the cursor will continue to step until the key is released. When the cursor reaches the edge of the page a bleep will sound, and will repeat until the key is released.

Notice how the grid reference on the Header changes as you move the cursor around.

3 Writing and Assigning Data

Numeric and alphanumeric entries

ATOMCALC accepts three types of input:

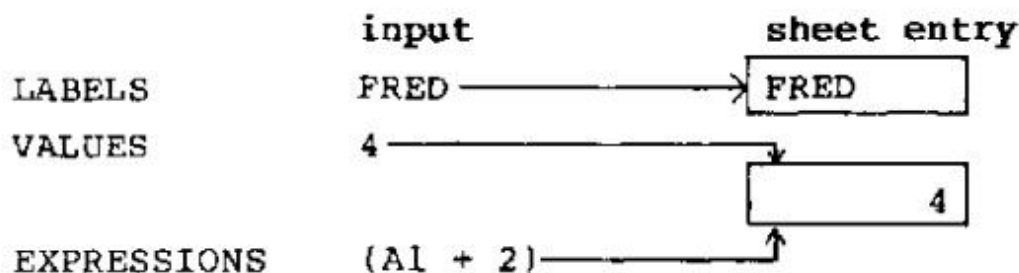

An expression can consist of just one grid reference (in which case the contents of the named cell are displayed) or a calculation involving numbers and functions.

As information is typed in it is displayed at line 3 of the header, immediately preceding the prompt. Press RETURN and the data is assigned to the cell currently highlighted by the cursor.

*Try this out by moving the cursor to A1 and entering "1981", and then pressing RETURN.

The letter "V" is displayed at line 1 of the header to show that this is a VALUE entry, and therefore one which can be used in future calculations.

*Move the cursor to B1, and enter the word "GAS".

An "L" is displayed at line 1 of the header: if the data is alphanumeric (other than the alphanumeric grid references) then the letter "L" is displayed to show that it is a LABEL entry.

As data is entered on to the sheet a copy of the entry is displayed at line 2 of the header, and remains there until the cursor is moved to a new grid reference. Whenever the cursor is returned to this position the full entry is displayed at the header.

*So, for example, if you move the cursor to grid reference C1 and enter "ELECTRICITY BILL" and only the first 8 letters are entered on the sheet, the full entry can always be found at line 2 of the header when the cursor is returned to this position. (Of course you may prefer to use a wider column width, and the full definition - see page 16.)

Calculations

You will find mathematical symbols on your keyboard as follows:

- + adds two numbers
- subtracts two numbers
- / divides two numbers
- * multiplies two numbers
- ^ raises to a power

When faced with a calculation containing several operands, ATOMCALC will always evaluate expressions in brackets before proceeding to evaluate the whole expression. Having evaluated the expressions in brackets, the precedence with which ATOMCALC performs calculations is as follows:

First ^
Second / *
Third + -

*This can be illustrated by comparing the answers to the expressions shown below (if you would like to try these out, move off to

a blank grid reference, G10 for example):

10+4/2 Answer: 12

(10+4)/2 Answer: 7

Note that the formula, not the answer, is displayed at line 2 of the header, so that whenever you return to this grid reference you can see exactly how the value on the sheet was calculated.

All arithmetic calculations are performed to 31 bit precision, giving better than 9 significant figures of accuracy to numbers in the range 1E-38 to 1E+38.

To set the format, enter /F followed by the number of decimal places required: for example,

/F4

Digits with more decimal places than allowed by the format control are truncated when displayed.

*For example,

using /F1, 9.9 is displayed as 9.9, but

using /F0, 9.9 is displayed as 9

However, the stored value, and therefore the one used in calculations, is 9.9.

(See also, 'Formatting', page 16.)

Calculations involving sheet entries

ATOMCALC is especially good at doing repetitive chores using values stored on the sheet. By way of illustration we shall return to grid reference A1 and proceed with our original example. As an alternative to using the cursor controls you can move the cursor directly to anywhere on the sheet with the command /G followed by your destination grid reference. So to go back to A1, the command is

/G A1

The photograph on the next page shows an extract from a household accounting system, part of which you have already entered on your ATOMCALC sheet. To calculate the average

monthly cost of gas the sum of the bills is divided by the number of months in a given period: June to November. The expression

$$(B2 + B3)/B4$$

is entered at B5, and the average is displayed on the sheet.

B5			ATOMCALC		
(B2+B3)/B4					
1981			GAS		ELEC
JUN-AUG		19	27		
SEP-NOV		23	39		
MONTHS		6	6		
AVERAGE		7	11		

If any of the values at B2, B3, or B4 are subsequently changed then the result at B5 is recalculated automatically.

*To illustrate this, complete the entries in column B, by entering "19" at B2, "23" at B3, and "6" at B4. At B5 enter the formula "(B2 + B3)/B4" and the average, 7, will be calculated and displayed when you press RETURN.

Now change B3 to "29" (you can 'write over' the old entry). The new average, 8, will be displayed at B5.

More about LABELS and VALUES

When labelling a column of numerical data you can put spaces in front of a LABEL so that it lines up with the figures beneath it, as in column C in the photograph above, where the entry was

----ELECTRICITY

where "-" represents one space.

Calculations and formulae are taken as VALUES so long as the calculation is possible, you steer clear of unattached letters, and take care to bracket grid references in all but the simplest cases.

If you enter an expression whose evaluation is impossible, it will be entered as a label: for example, SQR(A1), where the contents of A1 are negative. To force an expression to be accepted as a VALUE, so that the entry can be used in future recalculations, put a plus sign in front of the expression: "+SQR(A1)". The value of the cell will be displayed as ERROR until a positive value is entered at A1.

The following table shows some legal values and formulae:

1
1.500
(1+2) * 3/4
A1
A1 * 6
A1 + B1 - C1
(B3 + C1) / D1^2
(B2 * A4) / 3.3
A2 * 100 + BJ90 / 6
SIN (A1) * 3 + COS (A2) * 3
SQR(A1)

Scientific functions in ATOMCALC

ENTRY	FUNCTION	EXPLANATION	EXAMPLES
ABS	ABSOLUTE VALUE	Take positive value	ABS (A1)
ACS	ARC COSINE	Convert value to inverse cosine	ACS (A1) ACS 0.9857
ASN	ARC SINE	Convert value to inverse sine	ASN (A1) ASN 0.9857
ATN	ARC TANGENT	Convert value to inverse tangent	ATN (A1) ATN 0.9857
COS	COSINE	Calculate the cosine of the value	COS (A1) COS 0.9857
DEG	DEGREE	Convert the value to degrees from radians	DEG (A1) DEG (ACS(A1))
EXP	EXPONENT	Return a value expressed in standard form	EXP (A1)
FLT	FLOAT	*Force argument to be taken as an integer	FLT(2/3)
LOG	LOGARITHM	Calculate and display the natural logarithm	LOG (A1) LOG 0.9857
PI	PI	Present the constant π	PI * (A1)^2
RAD	RADIAN	Convert the value from degrees to radians	RAD (A1)
RND	RANDOM	*Generate a random number	RND
SGN	SIGN	-1, 0, +1 for negative, zero and positive arguments	SGN (A1) * A2
SIN	SINE	Convert value to sine	SIN (A1) SIN 0.9857
SQR	SQUARE ROOT	Calculate the square root of the value	SQR (A1) SQR 0.9857

Note: All trigonometrical values are displayed in Radians.

(* See the example on the next page.)

*To illustrate the use of FLT and RND enter the following:

"FLT (ABS RND * 10)"

When you press RETURN a random number between 0 and 9 is entered in the cell at the current cursor position. Press LOCK to generate another random number.

Where no limit is set, (for example, "RND") ATOMCALC will generate a random number between -2000 million and +2000 million.

4 Replicating

One of the most useful and flexible features of ATOMCALC is its replicating facility, whereby blocks of data or expressions can be copied from one area on the sheet to another.

Data

A block of data to be copied is defined by its top left grid reference and its bottom right grid reference, and the area that the block of data is being copied to is defined in the same way, as illustrated below:

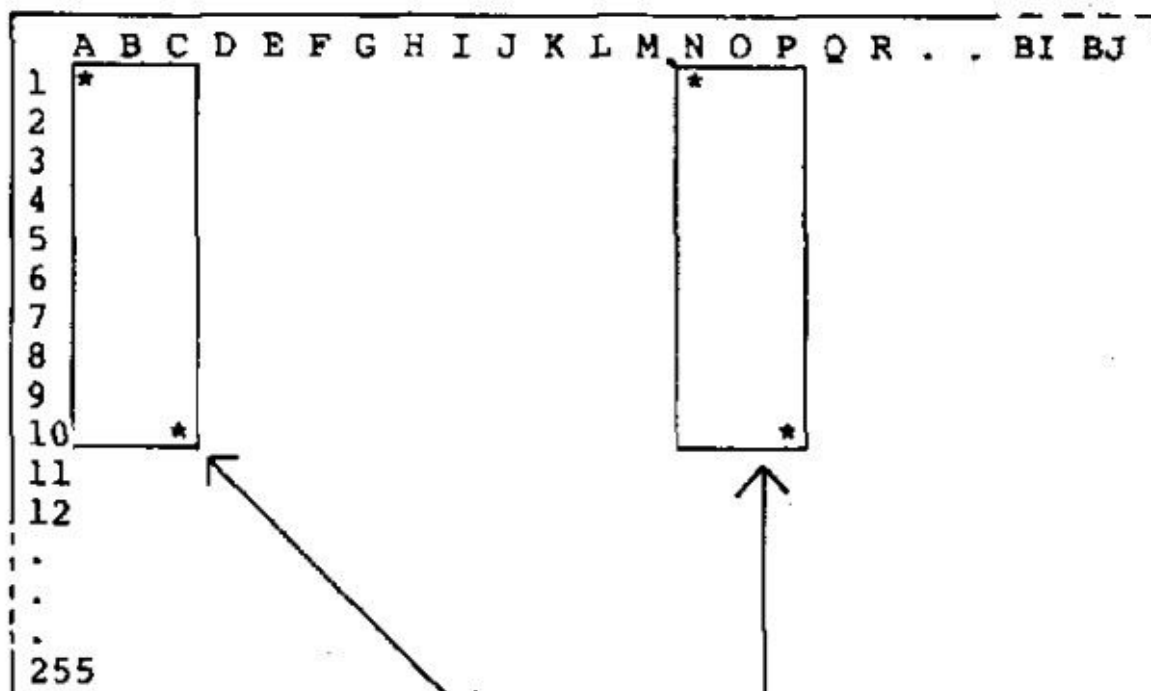

To copy data from here to here
enter /R A1 C10 N1 P10

*To demonstrate the replicating command,
enter the word "ATOMCALC" at position A1

and then press RETURN. Then enter the following:

/R	A1	A1	A1	E255
Replicate command	Block to be copied		Block to receive data	

The header will display the word "COPYING" for about one minute after which the word ATOMCALC will be displayed in columns A to E, in all 255 rows. The word "MEM" will appear at the top right hand side of the header showing that all 4403 bytes of memory have been allocated.

If only one entry is to be copied, the top left, and bottom right grid references will consist of only the one reference number:

*For example,

to copy	A1	to	C1
enter	/R	A1A1	C1C1

If you enter the command on its own, ATOMCALC will bleep, and ask you for the information it needs. Note that if you press RETURN after any command ATOMCALC will prompt you for the appropriate grid references or information.

To speed things up a little when entering replicate commands, will write the grid reference of the cell currently occupied by the cursor.

Expressions

ATOMCALC is capable of replicating a formula or a calculation exactly, or it can adjust each grid reference according to its relative position on the sheet.

*For example, consider the formula A1 + 1 being copied to 4 other positions. To do this, enter the number "1" at A1, move the cursor to A2 and enter the formula "A1 + 1": the resultant, 2, is displayed here. Enter the replicating command:

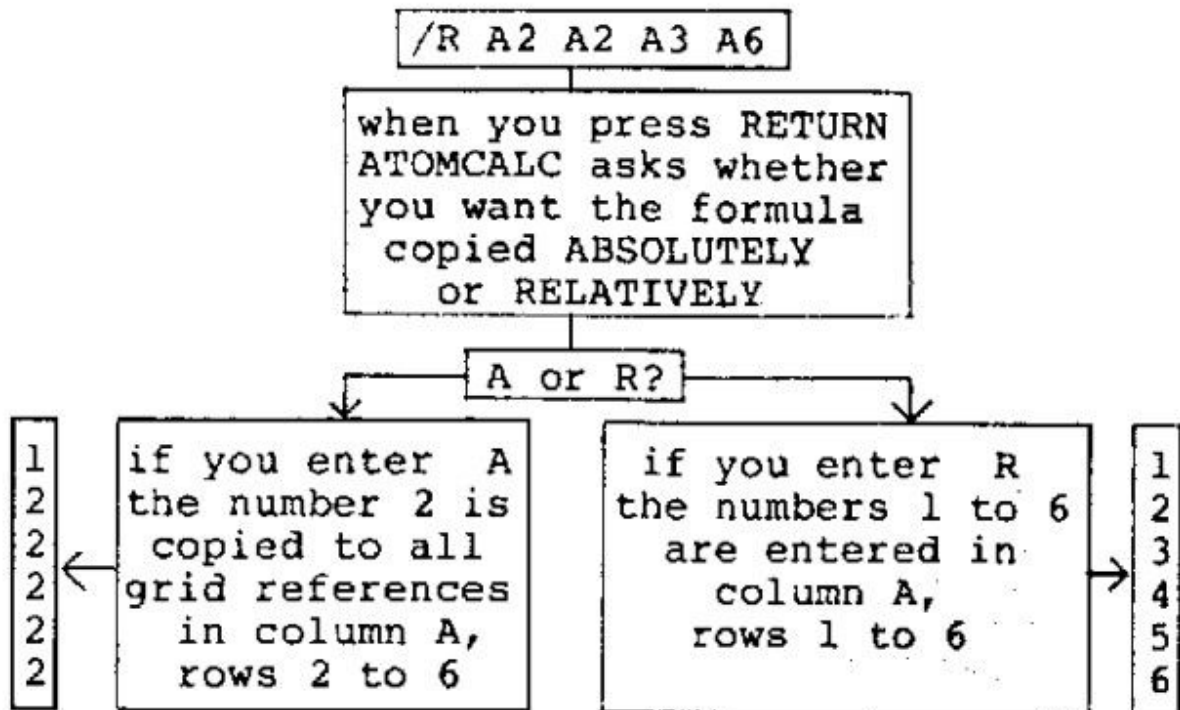

If the formula involves more than one sheet entry then the computer will repeat the question at each relevant stage of the formula, so that you can replicate one part of a formula absolutely, and another part relatively.

Manual control

Whenever new data is entered on the sheet, everything is recalculated automatically. When entering a large number of entries it is sometimes inconvenient to wait for ATOMCALC to recalculate the whole sheet as each entry is made. In this case, enter the command M, and you are in manual mode.

The ATOMCALC header displays an "M" on the first line. Once all entries have been made, press the LOCK key to recalculate everything on the sheet.

The following examples show how the replicating system works in practice.

Example A

In the interests of economy a telephone monitoring system has been installed in Mr J's office. A general overview of his monthly expenditure on telephone calls (pre-VAT) is shown in the photograph:

```
D6  V  ATOMCALC
B6 * C2
+
```

	UNITS	UNITCOST	COST
JAN	221.00	0.05	11.05
FEB	197.00		9.85
MAR	257.00		12.85
APR	236.00		11.80
MAY	248.00		12.40
JUN	251.00		12.55
JUL	264.00		13.20
AUG	269.00		13.45
SEP	236.00		11.80
OCT	274.00		13.70
NOV	256.00		12.80
DEC	237.00		11.85

The formula (B2 * C2) at D2 calculates the cost of X units at 5 pence per unit. The formula is replicated down the sheet with the command

```
/R D2 D2 D3 D13
```

When the replicate command is given, and the RETURN key pressed, ATOMCALC asks the question "A or R?" twice, referring to each grid reference in the formula in turn with a "?":

```
(B2 * C2)
  ?
```

enter (R) since this varies from month to month

```
(B2 * C2)
  ?
```

enter (A) since the unit cost is fixed

Example B

Set the format to 5 decimal places with the command "/F5":

```
enter "16" at A1, and "SQR (A1)" at B1
```

```
and /R B1 B1 C1 Z1
```

```
A or R?
```

```
enter (A) , and
the square root of
16 is entered in the
first row, columns
A to Z
```

```
enter (R) , and
the square roots of
16, 4, 2, etc. are
entered in the first
row, columns A to Z
```

Example C

This is how you can draw a simple bar chart composed of digits:

- 1 Set the format to 0 with the command `"/F0"`.
- 2 Enter some sample figures in column A as shown below. (For the purposes of this example you can assume that the figures represent the turnout, in thousands of people, to a series of ten football matches.)
Enter in column A, rows 1 to 10, the numbers 8, 5, 2, 3, 1, 7, 2, 3, 2, 6.
- 3 Move the cursor to B1 and set the column width to 12 characters wide with the command `/W12`.

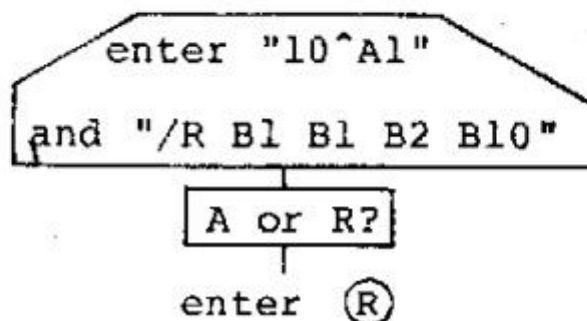

The photograph shows the resulting display:

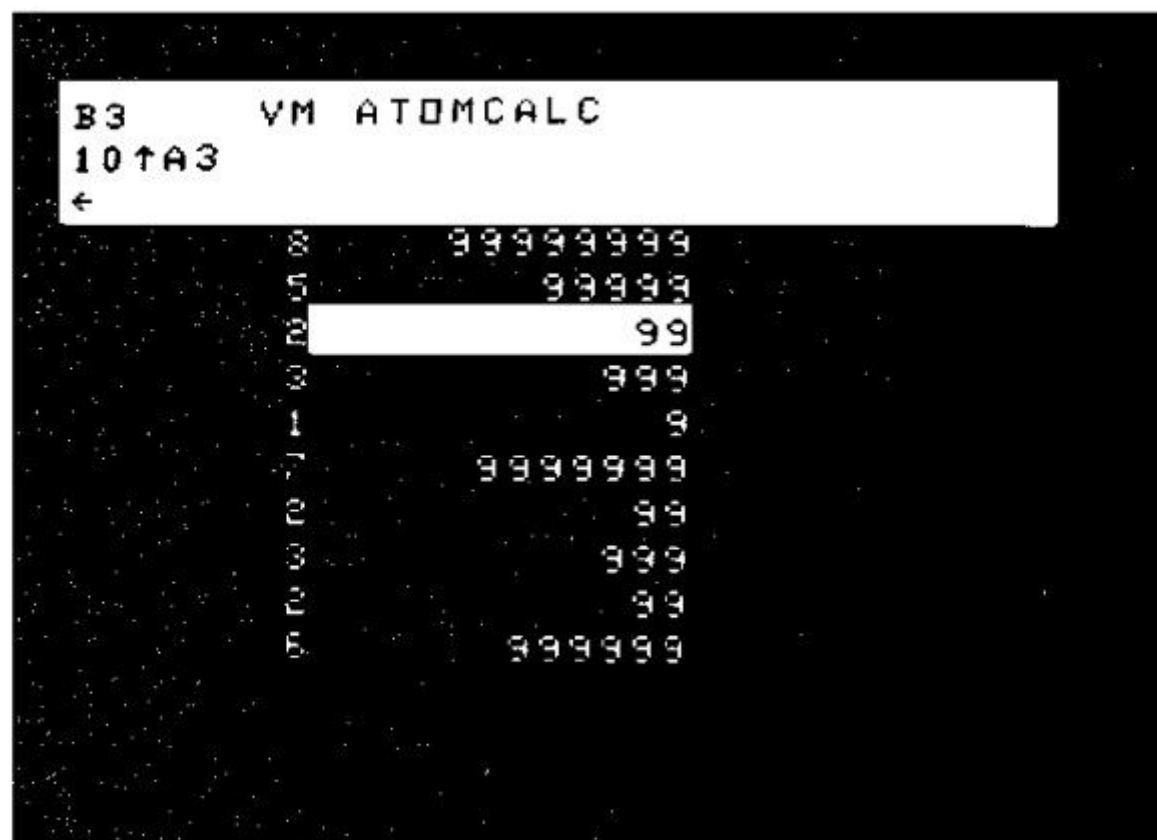

5 Deleting and Changing Entries

DELETE The DELETE key is used when correcting entries before they are written on to the sheet. DELETE will remove the character(s) immediately preceding the prompt. The bleep will sound when the cursor hits the left hand end of the header.

ESC The ESCape key is safe to use for escaping from any command, or clearing the input line, if you make a mistake while entering data.

To edit data which has already been entered on the sheet you can use the COPY key.

First, move the cursor to the grid reference in question.

COPY If only one character in a long word or equation is to be changed then use the COPY key to duplicate one character at a time until the change is required, when the new character is typed in. Press the COPY key to duplicate the rest of the entry and then press RETURN.

/B blanks an entry - enter **/B** and the space is freed when you press RETURN.

6 Presenting Data

Column width control

The column width is, by default 8 characters, but can be adjusted to anywhere between 0 and 32 characters by entering **/W** followed by your preferred width. For example,

/W20

Formatting

To set the format the command is

/F[n]

where n is an integer between 0 and 255. Where n lies between 0 and 31 ATOMCALC will attempt to display that number of decimal places. Once the format has been set it will apply to all subsequent entries until it is reset by another **/F** command.

For example, to set the format to 4 decimal places, enter

`/F4`

It is a good idea to set the number of decimal places required right at the start of an ATOMCALC session since if you change the format later on entries made prior to that point will not be altered.

If the column width is set too small to accommodate the result of a calculation in the specified format then the result is displayed in exponent form (e.g. 1.75E-8). However, exponent form requires a column width of at least 8 characters, and if the column width is set at less than 8, then a series of ?????? is displayed instead.

If the calculation is impossible (e.g. the square root of a negative number) then an ERROR message is displayed.

Fixing titles

The command `[/T]` fixes all rows and columns above and to the left of the cursor. Once titles have been assigned to any or all of the first row, and to any or all of the first column, they can be fixed by moving the cursor to cell B2 and entering `[/T]`. It is now impossible to move the cursor into row 1 and column A, and when the rest of the screen scrolls away to the right, or down, the titles stay put so that you can always refer to them.

To remove the restriction on titles, enter the command `[/U]`.

Negative quantities

The standard accountancy convention is to display negative quantities in brackets rather than prefixed with a minus sign. ATOMCALC can display negative quantities in either style: to change all negative quantities on the sheet from the prefixed to the bracketed style, enter `[/-]`. The same command `(/-)` is used to revert to scientific style.

Planning a print format

An A4, portrait, page will take 10 columns, each 8 characters wide, and approximately 54 rows. Printed out in this way the entire sheet would measure 7 pages across and 5 pages lengthways, which is 35 pages in all. However, it is much more likely that you will need to print out sections of the sheet, so if you bear the "80 characters by 54 rows" page format in mind when planning the layout of the ATOMCALC sheet, you can arrange the contents in a format which suits you, but which is also convenient for printing.

7 Saving, Loading, and Printing

Saving data

The sheet entries in columns A to BG can be saved on cassette. The procedure is described below:

- 1 Enter S - ATOMCALC responds with a request for "FILE?".
- 2 Enter a "FILENAME". When you press RETURN, ATOMCALC asks you to "RECORD TAPE".
- 3 Press the RECORD button on the cassette recorder, and then press the space bar to confirm that you have started recording. Two asterisks are displayed next to the "RECORD TAPE" message. When recording is complete the asterisks will disappear, so you know when you can switch off the cassette recorder.

Loading data

To load a file back from cassette:

- 1 Rewind the tape.
- 2 Enter L - ATOMCALC asks you for a "FILE?".
- 3 Enter the "FILENAME". When you press RETURN, ATOMCALC responds with an instruction to "PLAY TAPE".
- 4 Press PLAY on the cassette recorder and then press the space bar to confirm that you have done so. Two asterisks are displayed next to the "PLAY TAPE" message, and remain until loading is complete.

Listing the contents of a cassette

Just in case you've forgotten the name of your program, here's how to list the filenames on a cassette:

- 1 Rewind the tape.
- 2 Press BREAK to get into BASIC.
- 3 Enter "*CAT" and then press PLAY on the cassette recorder. As the tape is played the filenames on the cassette will be written on the screen.

If it doesn't work....

If all does not go smoothly with saving and loading data, use the checklist below:

- * Try a different volume setting on the cassette recorder.
- * Check that you are using the correct filename.
- * If you are using a tape that is slightly suspect, then exchange it for a newer, or better, one.
- * Try listing the filenames on cassette, and see whether there are any irregularities in the coding. For example, if the first part of a file is missing, then it may be something to do with the quality of the cassette.

Printing

Alternative print-outs are obtained using the `/O` and `/P` commands. Entering `/O` causes the full definitions of all sheet entries to be printed in a straight up-and-down format. `/P` prints the data on the sheet in tabular form, omitting any remarks or full definitions.

Output `/O`

The computer will print out all data and calculations within a defined block. The block is defined in the same way as for replicating, i.e. by the top left and the bottom right grid references.

*A typical command would be:

```
/O A1 D13
```

and would result in a 'hard copy' of the sheet entries in the defined area. Shown below is an extract from the output following this command, of some data from an experiment to compare the weight/height ratio of groups of seedlings grown under different conditions:

R1	L	GROUP
		GROUP
B1	L	HT(CMS)
		HT(CMS)
C1	L	WT(G)
		WT(G)
D1	L	WT/HT(G/CM)
		WT/HT(G/CM)
R2	V	1
1		
B2	V	13.85
13.85		
C2	V	48.98
48.9		
D2	V	3.53

Print /P

The contents of the sheet can be printed out in tabular form (as seen on the screen) using /P and the grid references defining the block to be printed. Similarly, any part of the sheet can be printed using /P and the block grid references.

*For example, columns A to D, and rows 1 to 13 of the same data shown in the /O extract above, would be printed out following the command

/P A1 D13

and would look like this:

GROUP	HT(CMS)	WT(G)	WT/HT(G/CM)
1	13.85	48.98	3.53
2	15.08	52.30	3.48
3	13.78	47.98	3.46
4	14.88	58.23	3.39
5	14.65	49.39	3.37
6	13.54	48.67	3.59
7	14.26	58.17	3.51
8	13.97	51.12	3.65
9	13.67	58.54	3.69
10	14.17	58.47	3.55
11	15.21	58.31	3.38
12	14.87	49.78	3.34

Example: A Cash Flow Forecast

A typical application involving financial data is the formulation of a cash flow forecast chart, which uses expectations based on past experience to predict the future cash requirements of a business. So, a cash flow prediction is a function of many factors, some fixed and some variable. In this example a small supermarket is predicting its cash requirements over the next 10 years.

Setting up a system

- 1 Assuming that the computer is switched on and ready to go press BREAK and then enter the command CALC.

The first column will contain headings for the breakdown of the company's finances, and the first row will have headings for the ten year progression.

- 2 First, set the width of the first column to 14 using the command `"/W14"`.

The forecast is for 10 years, so we will label columns B to K from 1 to 10 as follows:

With the cursor at position B1 enter the value 1, and then move the cursor to position C1 and enter the formula `"B1 + 1"`. Now enter `"/R C1 C1 D1 K1"` and to the question "A or R?", enter "R". The first row will now have 1 to 10 in columns B to K.

Move the cursor to position A2 and enter "SALES TURNOVER". Move the cursor down one position to A3 and enter "COST OF GOODS SOLD". The first three words appear at the cursor position and the full definition can be seen at line 2 of the header.

With the cursor at A4 enter "GROSS PROFIT". At position A5 enter 14 "=" symbols. Give the command `"/R A5 A5 B5 K5"` and the = = = = signs will be reproduced across the table - these will help separate items on the sheet.

To complete the labelling of the rows enter labels, and execute commands as listed in the table below:

Label	Grid Reference	Command
STAFF COSTS	A6	
STOCK COSTS	A7	
MAINTENANCE	A8	
RENTAL	A9	
=====	A10	/R A10 A10 B10 K10
NET PROFIT	A11	
=====	A12	/R A12 A12 B12 K12
INTEREST @ 10%	A13	
TAXATION @ 52%	A14	
DEPRECIATION	A15	
TAX DUE	A16	
=====	A17	/R A17 A17 B17 K17
CASH FLOW	A18	
=====	A19	/R A19 A19 B19 K19
SALES TURNOVER	A20	
YEAR	A21	
-----	A22	/R A22 A22 B22 K22

3 Rows and columns are now labelled. Move the cursor to position B2 and your display should resemble the photograph on the next page. It will be as well to fix the titles in place - they can always be un-fixed later - so with the cursor at B2 enter .

Setting the style

4 For dealings in pounds and pence two decimal places are required, so set the format with /F2.

Columns B to K may have to accommodate substantial sums of money and so we will set

the column widths to 10 with /W10 (you have to do this for each column).

Finally, we will instruct ATOMCALC to display negative quantities in brackets in true commercial style, so enter $\boxed{/ -}$.

```
B2          ATOMCALC
←
1
SALES TURNOVER
COST OF GOODS
GROSS PROFIT
=====
STAFF COSTS
STOCK COSTS
MAINTENANCE
RENTAL
=====
NET PROFIT
=====
INTEREST @10%
```

Entering data

Our shop is a new, medium-sized supermarket. The yearly sales turnover is expected to increase by a compound rate of 10% for the first ten years of the project. Compensation for inflation accounts for an annual increase of 9%.

- 5 We'll take an arbitrary figure of £10000 for the Sales Turnover for year 1, so enter "10000" at B2. Move the cursor to C2 and enter the formula "(B2*1.1) * 1.09". (From now on, for each stage, we will briefly describe the entries before listing them as they should be typed in, e.g.

at B2 enter "10000"

at C2 enter "(B2 * 1.1) * 1.09")

The rate of growth is constant, and so the

formula will be the same for the calculation of sales turnover each year. Replicate the formula across columns 2 to 10 as shown below, and when the calculation is complete the value 11990.00 should be displayed at C2.

/R C2 C2 D2 K2 (R)

- 6 The cost of the goods sold is 2/3rds of the value of Sales Turnover. With the cursor at position B3 enter the formula "B2/1.5". The value 6666.66 will be computed and displayed.

at B3 enter "B2/1.5"

/R B3 B3 C3 K3 (R)

- 7 Gross profit is calculated as the Sales Turnover minus the Cost of Goods Sold: the formula "B2 - B3" should be entered at position B4, and replicated relatively across the sheet.

at B4 enter "B2 - B3"

/R B4 B4 C4 K4 (R)

- 8 Staffing costs vary with Turnover and inflation. In order to calculate these costs a fixed cost of 12000 is entered in year 1 (position B6) and the formula "B6 * 1.1" applied to the second and each subsequent year.

at B6 enter "12000"

at C6 enter "B6 * 1.1"

/R C6 C6 D6 K6 (R)

- 9 The cost of holding the stocks that the supermarket will sell is calculated as being 2% of the value of Sales Turnover. The formula "B2 * 0.02" is entered at cursor position B7 and the value 200.00 should be displayed.

at B2 enter "B2 * 0.02"

/R B7 B7 C7 K7 (R)

- 10 Maintenance costs are expected to be £500.00 in the first year increasing by 10% p.a. thereafter. Enter 500 at position B8 and move the cursor to position C8 and enter the formula "B8 * 1.1". The formula is then copied relatively across the sheet.

at B8 enter "500"

at C8 enter "B8 * 1.1"

/R C8 C8 D8 K8 (R)

- 11 The rental is fixed and an annual charge of £4000.00 covers both the rental and the rates. Enter 4000 at position B9, and copy the value absolutely since the value at B9 is constant for the duration of the project.

at B9 enter "4000"

/R B9 B9 C9 K9 (A)

- 12 The Net Profit is calculated as the Gross Profit with other costs deducted, so at position B11 enter the formula "B4 - (B6 + B7 + B8 + B9)". The value (13366.66) will appear as the Net Profit for year 1 of the project. This formula is applied to each subsequent year of the project.

at B11 enter "B4 - (B6 + B7 + B8 + B9)"

/R B11 B11 C11 K11 (R) (R) (R) (R) (R)

- 13 Interest is accumulated over the period of one year on profits: but if the business makes a loss then interest must be paid. No interest is accumulated or paid in year 1, and therefore the value "0" is entered at position B13. In subsequent years interest accumulated or paid will amount to 10% of the profit or loss made by the business, so the formula B11 * 0.1 is replicated across the sheet in row 13.

at B13 enter "0"

at C13 enter "B11 * 0.1"

/R C13 C13 D13 K13 (R)

- 14 This stage requires the calculation of the taxation, at a rate of 52%, on the profits generated by the business. First, the Depreciation values must be entered on the sheet - these are set at £200 per year.

at B15 enter "200"

/R B15 B15 C15 K15 (A)

The Taxation row shows how much tax will be due in the following year, and is calculated as Net Profit plus Interest minus

Depreciation times 52%.

at C14 enter "(B11 + B13 - B15) * 0.52"

/R B14 B14 C14 K14 Ⓡ Ⓡ Ⓡ

15 Move the cursor to position B16 (the Tax Due row) and enter the value 0, because there is no tax due in the first year of the project. The Tax Due in subsequent years is shown in brackets so move the cursor to position C16 and enter "-B14" this will have the effect of transferring the value at position B14 and displaying it in brackets.

at B16 enter "0"

at C16 enter "-B14"

/R C16 C16 D16 K16 Ⓡ

16 The final item - the Cash Flow figure - is calculated by adding the Net Profit to the Interest, and subtracting the Tax due.

The Tax Due has already been calculated as a negative quantity, so in the formula, B16 will be added rather than subtracted.

at B18 enter "B11 + B13 + B16"

/R B18 B18 C18 K18 Ⓡ Ⓡ Ⓡ

```
A18  L  ATOMCALC
CASH FLOW
```

```

+
STOCK COSTS          200.00
MAINTENANCE          500.00
RENTAL               4000.00
=====
NET PROFIT           13366.66
=====
INTEREST @ 10%         0.00
TAXATION @ 52%       (7054.66)
DEPRECIATION         200.00
TAX DUE              0.00
=====
CASH FLOW            13366.66
=====
```

17 The remaining two rows are copies of rows 1 and 2, displaying the annual turnover so that it may be seen in relation to the final Cash Flow figure.

at B20 enter "B2"

/R B20 B20 C20 K20 (R)

at B21 enter "B1"

/R B21 B21 C21 K21 (R)

In conclusion

The Cash Flow Forecast chart is now finished, and you can see from the photograph that a turnover of £10,000.00 in the first year will result in a negative cash flow of £13366.66; this means that the business will be spending more than it takes.

Looking at the chart it can be seen that negative cash flows are generated every year. By increasing the figure at B2, you can speculate as to the size of turnover required to break even. Enter the value "52659.6" at B2 and this will result in the cash flow forecast equalling the break even point. Any increase in revenue will increase the profitability of the business. (NB This assumption is based upon strict accounting theory: economic theory is slightly different!)

Now that data and expressions have been entered on to the sheet questions can be asked and solved quickly and accurately, for example;

What happens if the rent goes up to £6000.00?

What if the Government changes the Tax rate?

What Turnover is needed to make the shop break even in year 4?

What happens if the staff threaten to strike unless they get a 20% pay rise?

What happens if Maintenance or Stock costs change?

What if the Sales Forecast is wrong?

By simply moving the cursor to appropriate positions and changing raw data entries these and many other hypotheses can be tested, proved or disproved.

Subject index

ABS 10, 11
absolute replicating 13
accuracy 7
ACS 10
ASN 10
ATN 10

bar chart 15
BASIC 3, 19
blank (command) 16
BREAK 3, 19

CALC 3
CALCR 3
calculations 6ff
column width 16
COPY 16
COS 10
cursor 4

DEG 10
DELETE 16
display 4

enter: ATOMCALC 3
sheet entry 5
ERROR messages 9, 17
ESCAPE 16
EXP 10
expressions 5

filename 18
FLT 10, 11
format 7, 16, 22
functions 10

Go (command) 7
header 3
input 5

LABELS 5, 8
legal values 9
listing contents of cassette 19
Loading from cassette 18
LOCK 3, 13
LOG 10

manual control 13
memory 2, 12

negative quantities 17

output 19

PI 10
print 19, 20
print format 18
precedence 6
presentation 16ff

RAD 10
recalculation 8, 13
replicating 11ff
data 11
expressions 12
relative replicating 13
RND 10, 11

Saving on cassette 18ff
scientific functions 10
SGN 10
SIN 10
SQR 9, 10

titles 17, 32
TOP Back cover

VALUES 5, 8

Acornsoft Limited

4a Market Hill, Cambridge CB2 3NJ, England. Telephone 316039

SUMMARY OF COMMANDS

Command	Meaning	Page
CALC	Enter ATOMCALC from BASIC	3
CALCR	Return to ATOMCALC at position of exit retaining all data	3
LOCK	Recalculate all sheet entries	3
BREAK	Revert to BASIC	3
RETURN	Terminate user input	3
COPY	Duplicate entry at header	16
DELETE	Remove character immediately preceeding '←' prompt	16
↔ & ↑	Cursor movement controls	5
SHIFT	Reverse cursor movement	5
\	Enter grid reference of cell currently occupied by cursor	12
/G [#]	Move cursor directly	7
/B [#]	Blank sheet entry	16
/F [n]	Control decimal place format	7,16
/L [FILE]	Load from cassette	18
/M	Put ATOMCALC into, and out of, manual mode	13
/O [##]	Output full definition of sheet entries	19
/P [##]	Print out sheet	20
/R [####]	Replicate a block	11
/S [FILE]	Save the contents of the sheet	18
/T	Fix title	17
/U	Remove /T restrictions	17
/W [n]	Set column width	16
TOP	Display memory available in bytes	-
/-	Adopt commercial style i.e. negative items in brackets, and revert to scientific style	17

Note: for the purposes of this summary, the # character denotes one grid reference.